

KF720 Specifications



FEATURES

- Ultra-compact, three-way line array module
- Advanced, easy-to-operate rigging system
- Exceptional pattern control due to symmetrical design, large horn and Phase-Aligned™ woofers
- Incorporates core EAW technologies including CSA™ and Focusing™ for outstanding mid and high frequency transient response

APPLICATIONS

Theaters, houses of worship, corporate A/V, small music venues

DESCRIPTION

KF720 delivers the three-way design, power and fidelity of the KF Series line array systems in an ultra-compact enclosure weighing less than 44 lbs. (19.8 kg). The exceptional output capability in a small, lightweight package allows KF720 to fill a range of application requirements from small theaters and houses of worship to live concerts and corporate events.

KF720 features an internal, passive MF/HF crossover filter network to deliver bi-amplified powering of the three-way system. Dual 6-in LF cone transducers in a sealed enclosure deliver horizontal pattern control via tuned spacing. Dual 6-in MF cone transducers are mounted in a large horn that fills virtually the entire face of the enclosure, maximizing horizontal pattern control as well as driver efficiency. Six 1-in dome tweeter HF transducers share the same horn with the MF transducers; tightly stacked in the center of the enclosure, the six HF transducers leverage beneficial interaction to generate extraordinary output. The three subsystems feature a symmetrical configuration, allowing coherent summation and even response across the nominal 110 degree (h) by 12 degree (v) coverage area.

The KF720 flybar works on its own or, via an adapter, can attach to an NTS250 dual 15-in subwoofer. The KF720 flybar also features adjustable footpads so that users can invert it and use it to safely ground-stack up to six KF720 modules. The ingenious rigging system allows users to select a range of module-to-module angles, which simply snaps into place to create a safe, strong connection between modules. In the unlikely event of a module failure, users can quickly and easily remove the module from within the rigging structure and replace it without ever disassembling the array.

Six year loudspeaker warranty.

3-WAY FULL-RANGE LOUDSPEAKER

See *NOTES TABULAR DATA* for details

CONFIGURATION

Subsystem:	Transducer	Loading
	LF 2 × 6 in, 1.75 in voice coil cone driver	Sealed, Phase Aligned™
	MF 2 × 6 in, 1.75 in voice coil cone driver	Sealed, Horn-loaded w/ CSA™ Aperture
	HF 6 × 1 in dome tweeter	Horn-loaded

Operating Mode:	Amplifier Channels	External Signal Processing
Bi-amp (Passive MF/HF)	LF, MF/HF	DSP w/EAW Focusing

PERFORMANCE

Operating Range: 75 Hz to 19 kHz

Nominal Beamwidth:

Horz 110°

Vert 12°

Axial Sensitivity (whole space SPL):

LF 88 dB 75 Hz to 400 Hz

MF/HF 99 dB 85 Hz to 19 kHz

Input Impedance (ohms)

Nominal

LF 16 12.6 @ 450 Hz

MF /HF 16 12.9 @ 250 Hz

High Pass Filter

High Pass =>80 Hz, 24 dB/octave Butterworth

Accelerated Life Test

LF 62 V 240 W @ 16 ohm

MF/HF 60 V 225 W @ 16 ohm

Calculated Axial Output Limit (whole space SPL)

Average

LF 112 dB 118 dB

MF/HF 122 dB 126 dB

ORDERING DATA

Description	Part Number
EAW KF720 3-Way Full-Range Loudspeaker Black	2039220-90
Optional Accessories	
EAW KF720 Flybar [FB172]	0023890
EAW FB172 Ground Stack Kit [ACC-GS172]	0020646
EAW KF720 Flybar & FB172 Ground Stack Kit [FB172GS]	0025596
EAW Pull Bar NTL720 [PB172]	0023891
EAW Spare Pin QR BH 6 X 27.5 (lanyard) [SP-QRPN]	0020963
Pin/Quick Release/Large Button/6mm X 38.1 w/Lanyard	0020964

KF LINE SOURCE VOICING UPDATE Leveraging data and experience from development of Adaptive Systems™, updated Greybox™ processing enhances performance of KF720, incorporating improved equalization, crossover, Focusing™ and limiting parameters for even better system performance without physical changes. The update brings improved warmth and clarity to the system, while making it sonically more consistent with KF730, KF740 and Adaptive Systems. Updated Greyboxes™ are available on the EAW website, www.eaw.com



KF720 Specifications

ENCLOSURE

Material Exterior-grade Baltic birch plywood

Finish Roadcoat™ wear resistant textured black paint

Grille Powder-coated perforated steel

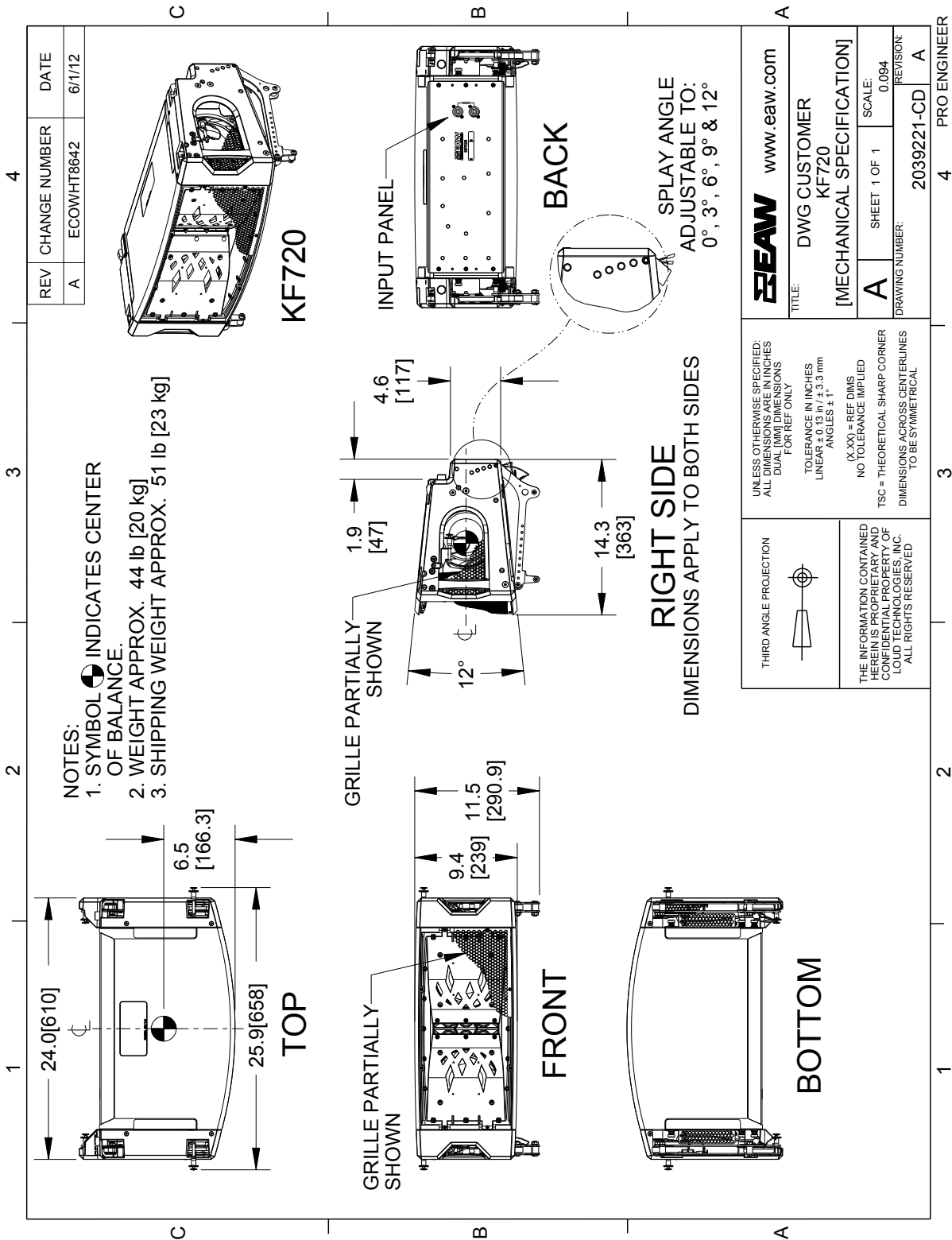

NOTE: This drawing has been reduced. Do not scale.

PERFORMANCE DATA

See *NOTES GRAPHIC DATA* for details

Frequency Response: Processed

LF = green, HF = black, Complete = blue

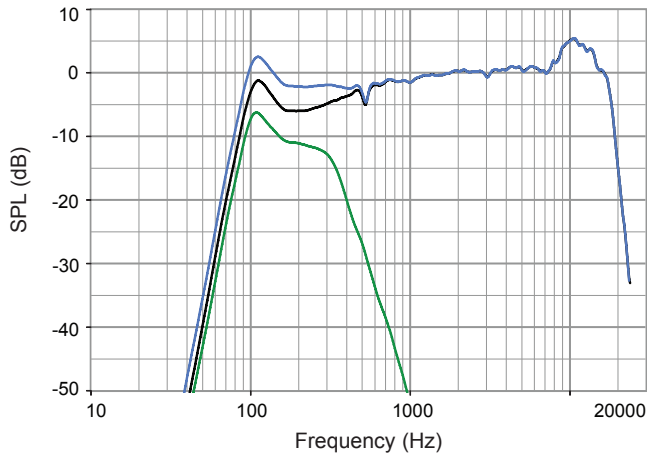

Frequency Response: Unprocessed

LF = green, HF = black

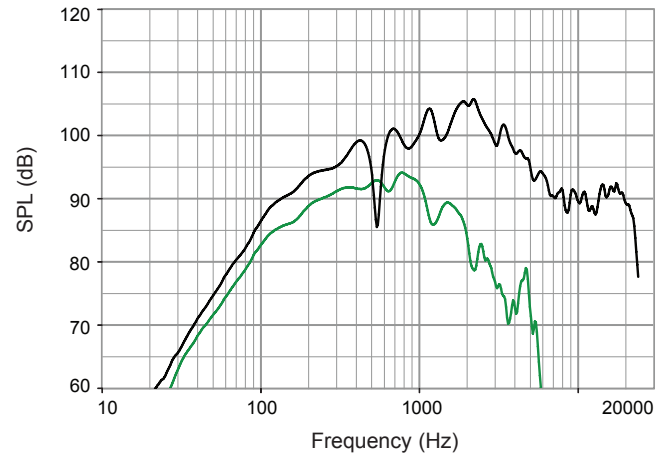

Impedance

LF = green, HF = black

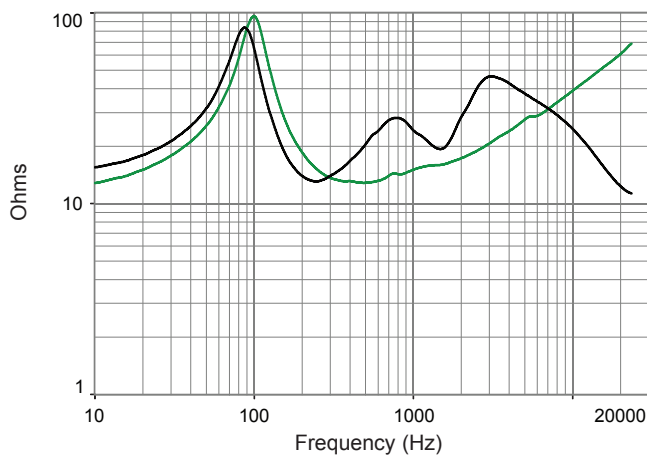

Phase Linearity

Complete = blue

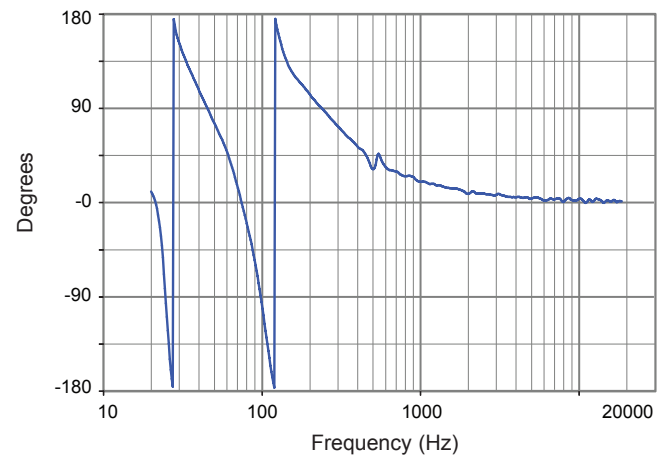

Beamwidth

Horizontal = orange Vertical = black

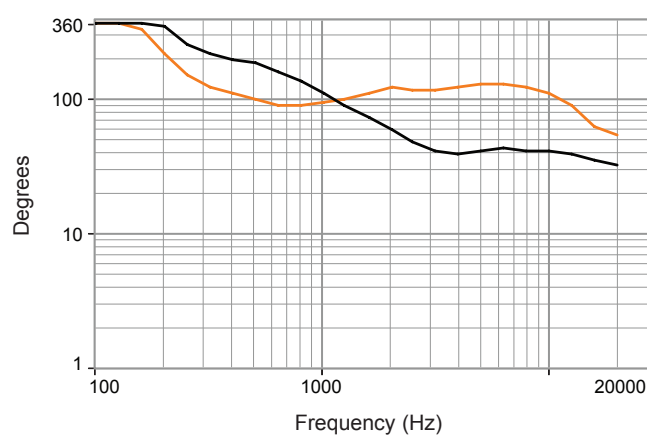

HORIZONTAL POLAR DATA

See *NOTES GRAPHIC DATA* for details

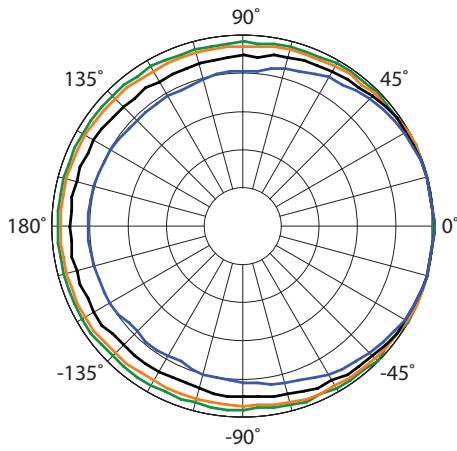

- 100Hz
- 125Hz
- 160Hz
- 200Hz

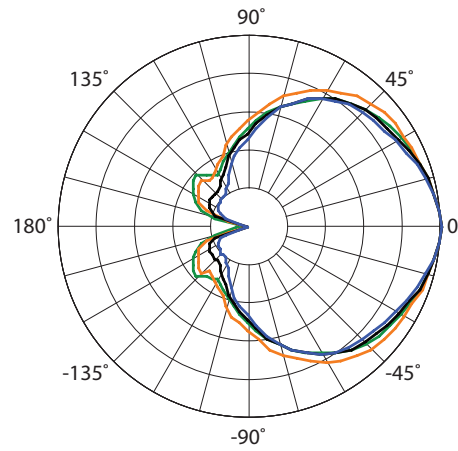

- 1600Hz
- 2000Hz
- 2500Hz
- 3150Hz

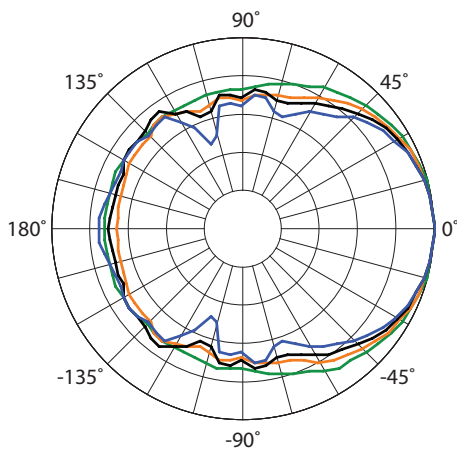

- 250Hz
- 315Hz
- 400Hz
- 500Hz

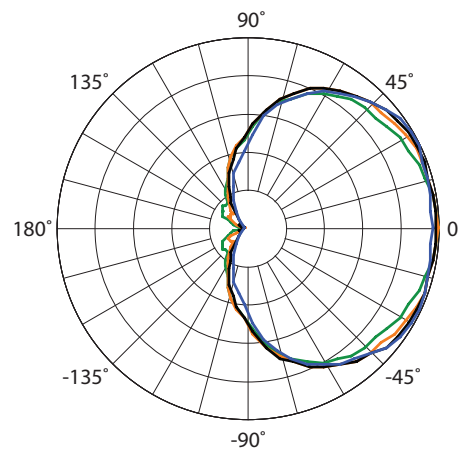

- 4000Hz
- 5000Hz
- 6300Hz
- 8000Hz

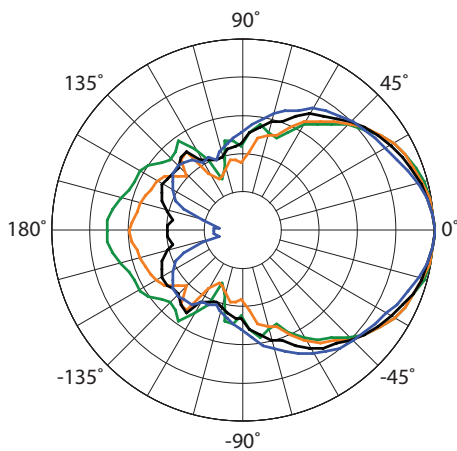

- 630Hz
- 800Hz
- 1000Hz
- 1250Hz

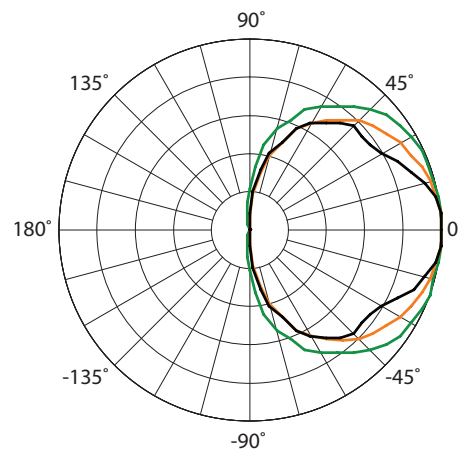

- 10000Hz
- 12500Hz
- 16000Hz

VERTICAL POLAR DATA

See *NOTES GRAPHIC DATA* for details

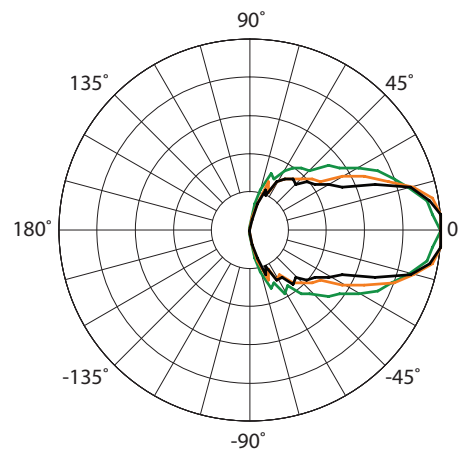
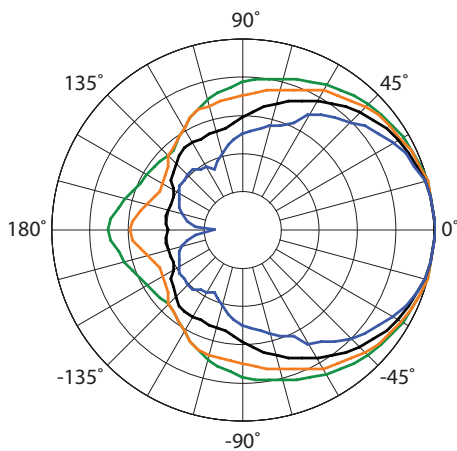
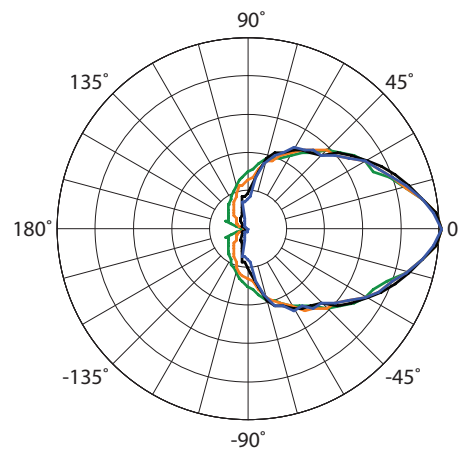
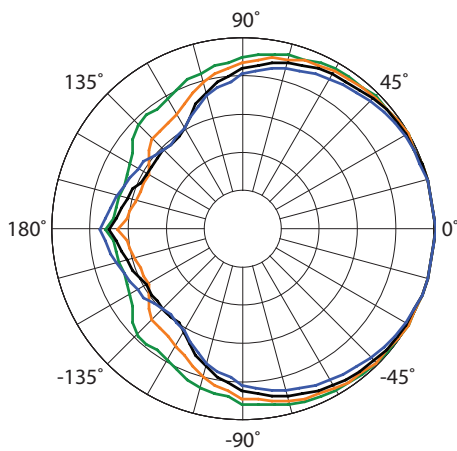
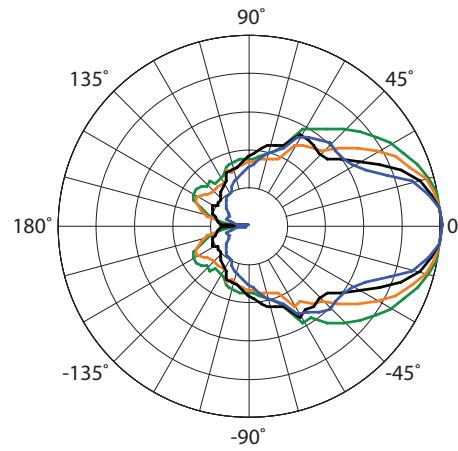
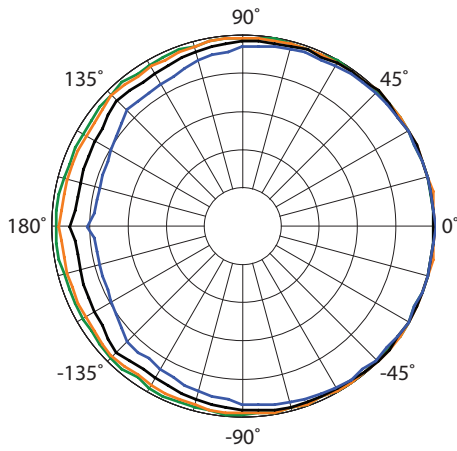

KF720 Specifications

INPUT PANEL

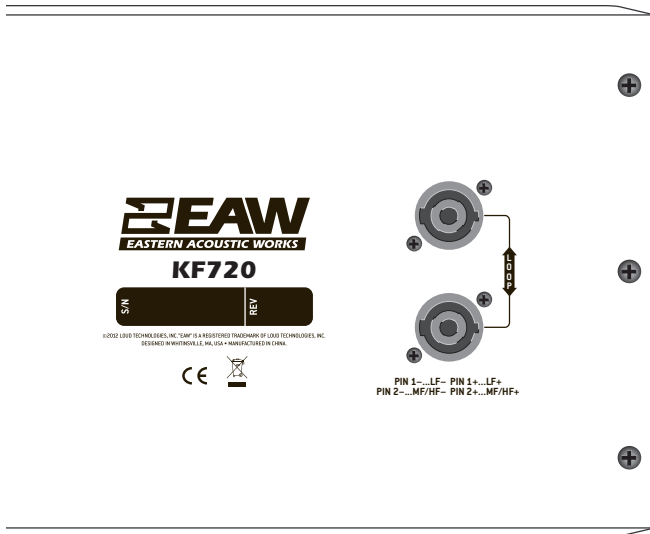

SIGNAL DIAGRAM

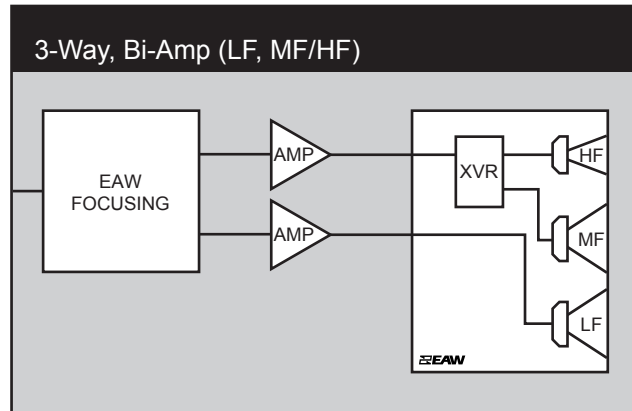

LEGEND

- HPF:** High Pass Filter for crossover –or– Recommended High Pass Filter.
- LPF:** Low Pass Filter for crossover.
- LF/MF/HF:** Low Frequency / Mid Frequency / High Frequency.
- AMP:** User Supplied Power Amplifier –or– Integral Amplifier for NT products.
- XVR:** Passive LPFs, HPFs, and EQ integral to the loudspeaker.
- EAW Focusing:** Digital Signal Processor capable of implementing EAW Focusing.

NOTES

TABULAR DATA

1. **Measurement/Data Processing Systems:** Primary - FChart: proprietary EAW software; Secondary - Brüel & Kjær 2012.
2. **Microphone Systems:** Earthworks M30; Brüel & Kjær 4133
3. **Measurements:** Dual channel FFT; length: 32 768 samples; sample rate: 48 kHz; logarithmic sine wave sweep.
4. **Measurement System Qualification** (includes all uncertainties): SPL: accuracy +/-0.2 dB @ 1 kHz, precision +/-0.5 dB 20 Hz to 20 kHz, resolution 0.05 dB; Frequency: accuracy +/-1 %, precision +/-0.1 Hz, resolution the larger of 1.5 Hz or 1/48 octave; Time: accuracy +/-10.4 μ s, precision +/-0.5 μ s, resolution 10.4 μ s; Angular: accuracy +/-1°, precision +/-0.5°, resolution 0.5°.
5. **Environment:** Measurements time-windowed and processed to eliminate room effects, approximating an anechoic environment. Data processed as anechoic or fractional space, as noted.
6. **Measurement Distance:** 7.46 m. Acoustic responses represent complex summation of the subsystems at 20 m. SPL is referenced to other distances using the Inverse Square Law.
7. **Enclosure Orientation:** For beamwidth and polar specifications, as shown in Mechanical Specification drawing.
8. **Volts:** Measured rms value of the test signal.
9. **Watts:** Per audio industry practice, "loudspeaker watts" are calculated as voltage squared divided by rated nominal impedance. Thus, these are not True Watt units of energy as defined by International Standard.
10. **SPL:** (Sound Pressure Level) Equivalent to the average level of a signal referenced to 0 dB SPL = 20 microPascals.
11. **Subsystem:** This lists the transducer(s) and their acoustic loading for each passband. Sub = Subwoofer, LF = Low Frequency, MF = Mid Frequency, HF = High Frequency.
12. **Operating Mode:** User selectable configurations. Between system elements, a comma (,) = separate amplifier channels; a slash (/) = single amplifier channel. DSP = Digital Signal Processor. IMPORTANT: To achieve the specified performance, the listed external signal processing must be used with EAW-provided settings.
13. **Operating Range:** Range where the processed Frequency Response stays within -10 dB SPL of the power averaged SPL within this range; measured on the geometric axis. Narrow band dips are excepted.
14. **Nominal Beamwidth:** Design angle for the -6 dB SPL points, referenced to 0 dB SPL as the highest level.
15. **Axial Sensitivity:** Power averaged SPL over the Operating Range with an input voltage that would produce 1 W at the nominal impedance; measured with no external processing on the geometric axis, referenced to 1 m.
16. **Nominal Impedance:** Selected 4, 8, or 16 ohm resistance such that the minimum impedance point is no more than 20% below this resistance over the Operating Range.
17. **Accelerated Life Test:** Maximum test input voltage applied with an EIA-426B defined spectrum; measured with recommended signal processing and Recommended Protection Filter.
18. **Calculated Axial Output Limit:** Highest average and peak SPLs possible during the Accelerated Life Test. The Peak SPL represents the 2:1 (6 dB) crest factor of the Life Test signal.
19. **High Pass Filter:** This helps protect the loudspeaker from excessive input signal levels at frequencies below the Operating Range.

GRAPHIC DATA

1. **Resolution:** To remove insignificant fine details, 1/12 octave cepstral smoothing was applied to acoustic frequency responses and 1/3 octave cepstral smoothing was applied to the beamwidth and impedance data. Other graphs are plotted using raw data.
2. **Frequency Responses:** Variation in acoustic output level with frequency for a constant input signal. Processed: normalized to 0 dB SPL. Unprocessed inputs: 2 V (4 ohm nominal impedance), 2.83 V (8 ohm nominal impedance), or 4 V (16 ohm nominal impedance) referenced to a distance of 1 m.
3. **Processor Response:** The variation in output level with frequency for a constant input signal of 0.775 V = 0 dB reference.
4. **Beamwidth:** Average angle for each 1/3 octave frequency band where, starting from the rear of the loudspeaker, the output first reaches -6 dB SPL referenced to 0 dB SPL as the highest level. This method means the output may drop below -6 dB SPL within the beamwidth angle.
5. **Impedance:** Variation in impedance magnitude, in ohms, with frequency without regard to voltage/current phase. This means the impedance values may not be used to calculate True Watts (see 9 above).
6. **Polar Data:** Horizontal and vertical polar responses for each 1/3 octave frequency band 100 Hz to 16 kHz or Operating Range.