

# VFM129i Specifications



## FEATURES

- Two-way, full range loudspeaker
- Classic stage monitor design
- Pole mount cup (black version only) for use as main system
- Large, user-rotatable horn for optimized pattern control
- Beamwidth-matching crossover point
- Long-lasting reliability

## APPLICATIONS

Band PA, DJ System, Dance Club, Schools, Houses of Worship, Rental Systems, Mobile Churches, Auditoriums

## DESCRIPTION

The VFM129i two-way, stage monitor loudspeaker system includes a direct-radiating, vented, 12-in LF cone transducer and a 1-in exit / 1.75-in voice coil HF compression driver loaded with a large, square, user-rotatable 90x60 coverage pattern horn.

Because VF Series full range systems (VFR/VFM) use HF sections similar to those developed for the MK Series, EAW engineers could employ the same revolutionary "beamwidth-matching" internal passive crossover/filter networks that set the MK Series apart from all other two-way systems. If powered by an EAW-specified amplifier or via a UX Series digital signal processor, the VFM129i can enjoy the benefits of EAW Focusing, a technology that eliminates the anomalies inherent in the time domain of any loudspeaker.

The VFM129i features a classic stage monitor design with NL4 connectors located on both sides for easy loop-through connections. They also include a pole mount cup should they need to be used as small PA mains. Engineers integrated the handles into the enclosure design, giving the low-profile enclosure a sleek, clean appearance.

Six year warranty.

## 2-WAY FULL-RANGE STAGE MONITOR

See *NOTES TABULAR DATA* for details

### CONFIGURATION

#### Subsystem:

	<b>Transducer</b>	<b>Loading</b>
LF	1× 12 in cone	Vented
HF	1× 1 in exit, 1.75 in voice coil compression driver	Horn-loaded

#### Operating Mode:

	<b>Amplifier Channels</b>	<b>External Signal Processing</b>
	Single-amp LF/HF	High pass filter

### PERFORMANCE

**Operating Range:** 65 Hz to 20 kHz

**Nominal Beamwidth (rotatable):**

Horz 90°  
Vert 60°

**Axial Sensitivity (whole space SPL):**

LF/HF 94 dB 65 Hz to 20 kHz

**Input Impedance (ohms):**

	<b>Nominal</b>	<b>Minimum</b>
LF/HF	8	9 @ 148 Hz

**High Pass Filter:** High Pass =>50 Hz, 12 dB/octave Butterworth

**Accelerated Life Test:**

LF/HF 63.2 V 500 W @ 8 ohm

**Calculated Axial Output Limit (whole space SPL):**

	<b>Average</b>	<b>Peak</b>
LF/HF	121 dB	127 dB

### ORDERING DATA

<b>Description</b>	<b>Part Number</b>
EAW VFM129i 2-Way Full-Range Stage Monitor Black	2041023-90
EAW VFM129i 2-Way Full-Range Stage Monitor White	2041040-90

# VFM129i Specifications

## ENCLOSURE

- Material Exterior-grade Baltic birch plywood
- Finish Wear resistant textured black paint
- Grille Powder-coated perforated steel

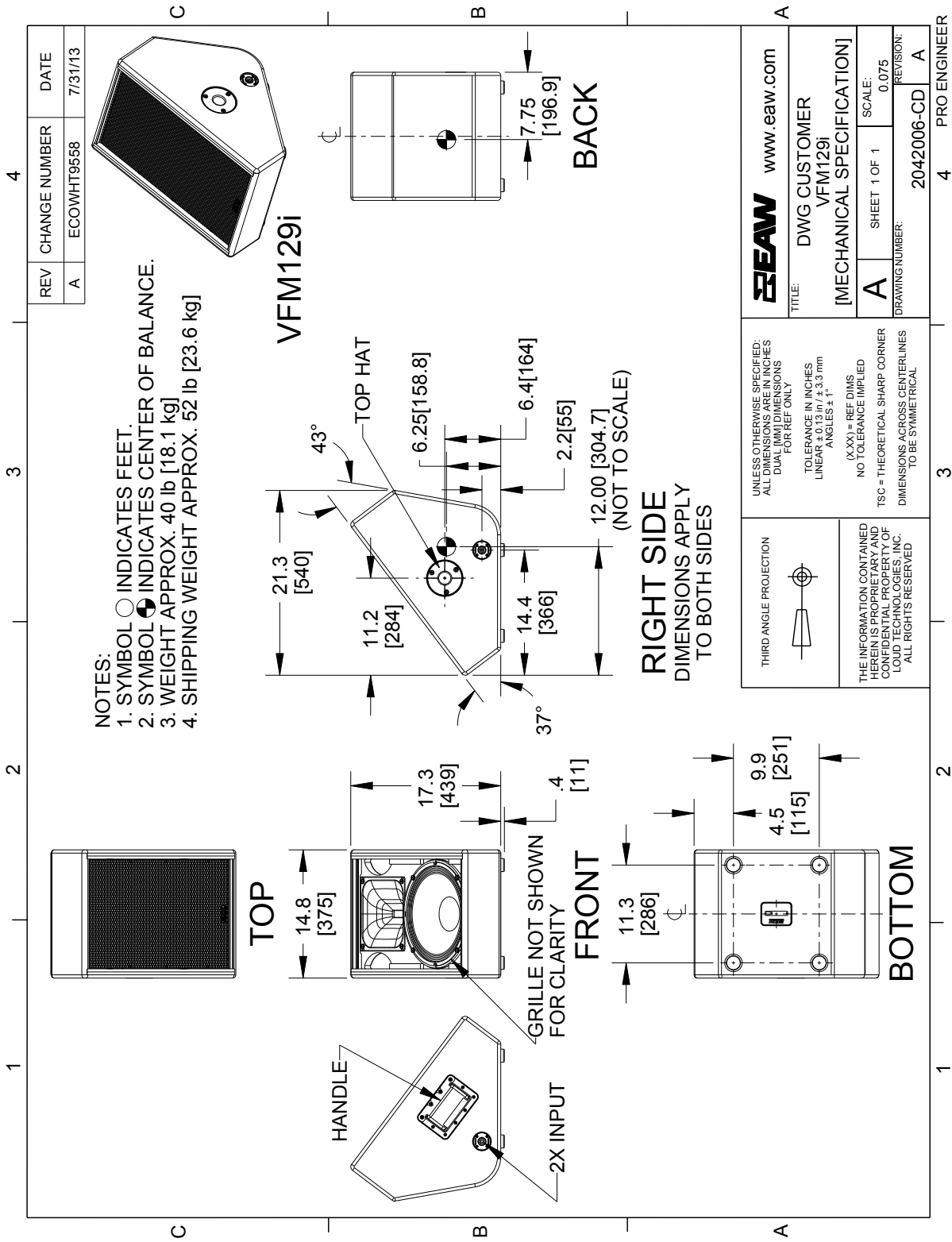

**NOTE:** This drawing has been reduced. Do not scale.



# VFM129i Specifications

## ENCLOSURE

- Material Exterior-grade Baltic birch plywood
- Finish Wear resistant textured white paint
- Grille Powder-coated perforated steel

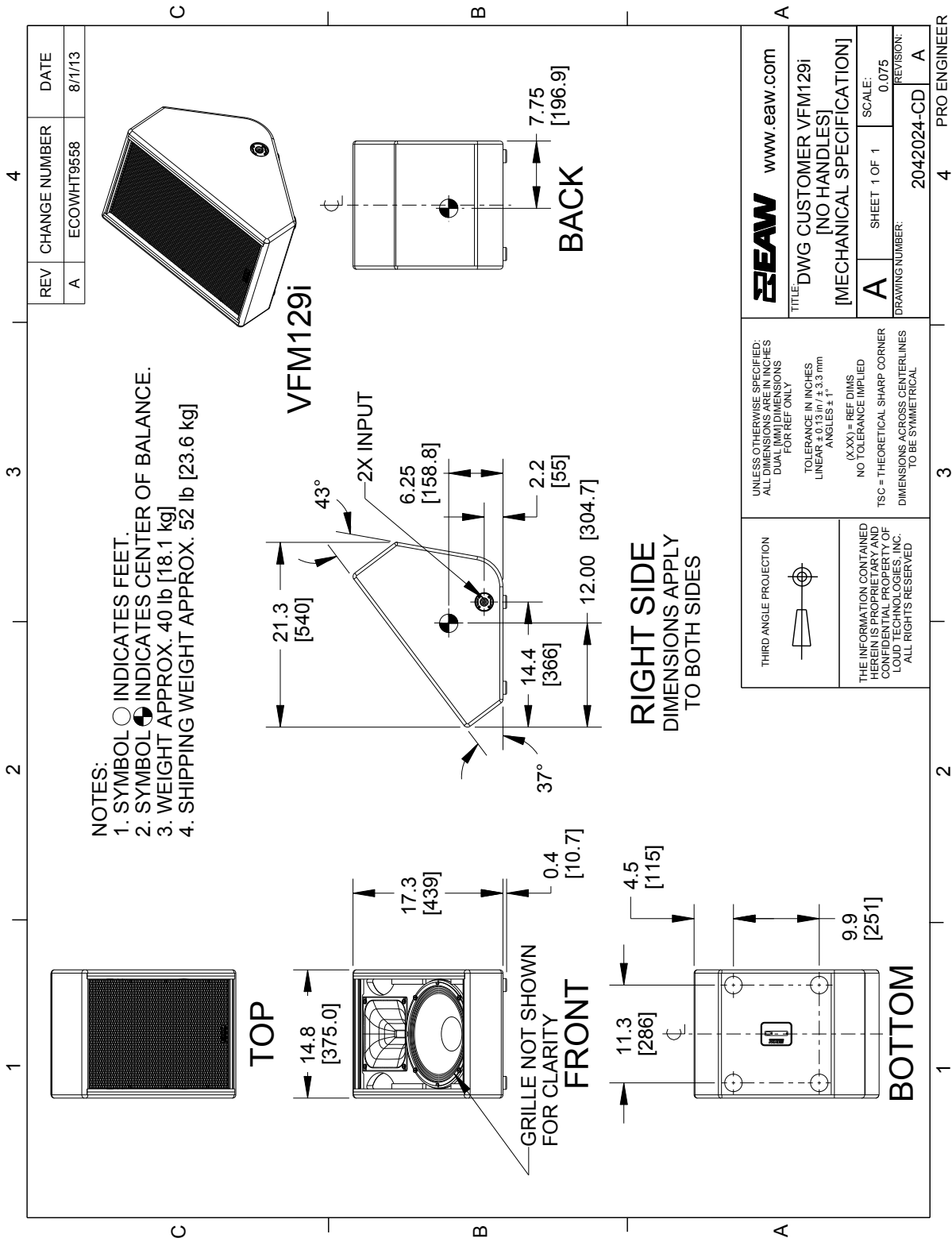

**NOTE:** This drawing has been reduced. Do not scale.



# VFM129i Specifications

## PERFORMANCE DATA

See *NOTES GRAPHIC DATA* for details

### Frequency Response: Processed

Complete = blue

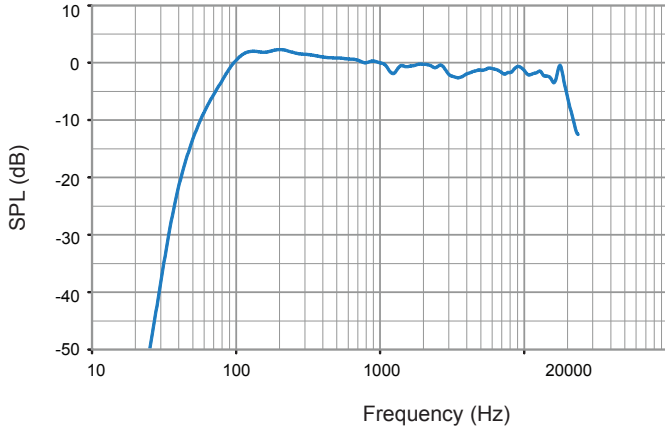

### Frequency Response: Unprocessed

Complete = blue

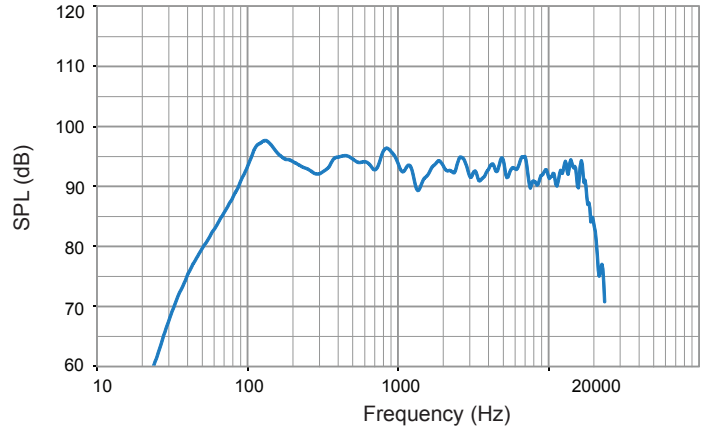

### Impedance

Complete = blue

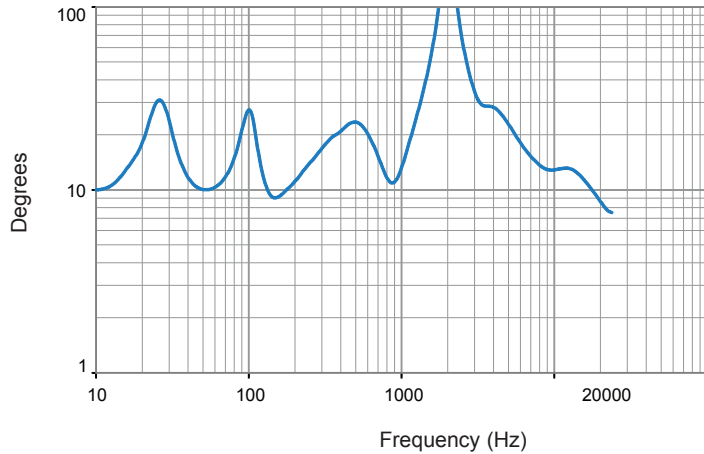

### Phase Linearity

Complete = blue

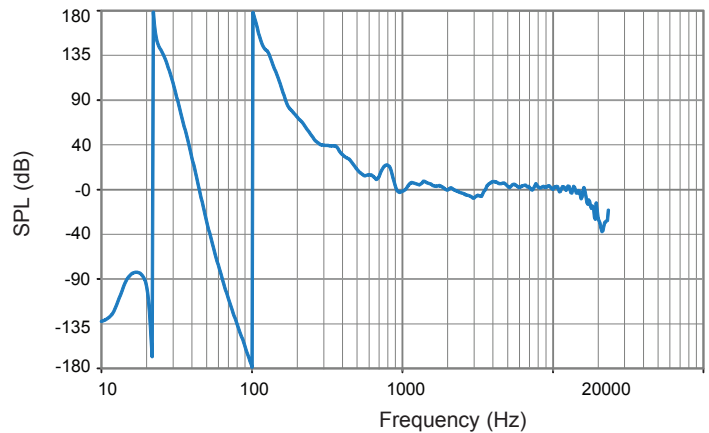

### Beamwidth

Horizontal = orange Vertical = black

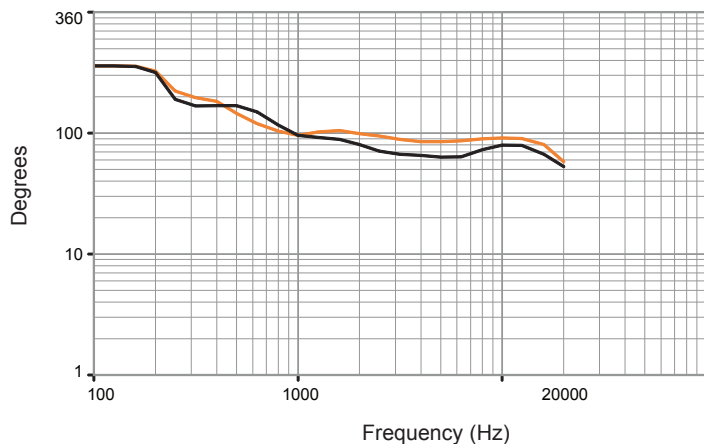

# VFM129i Specifications

## HORIZONTAL POLAR DATA

See *NOTES GRAPHIC DATA* for details

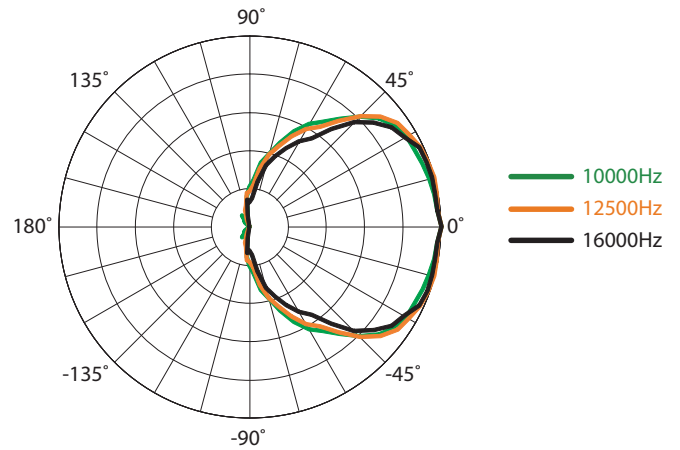
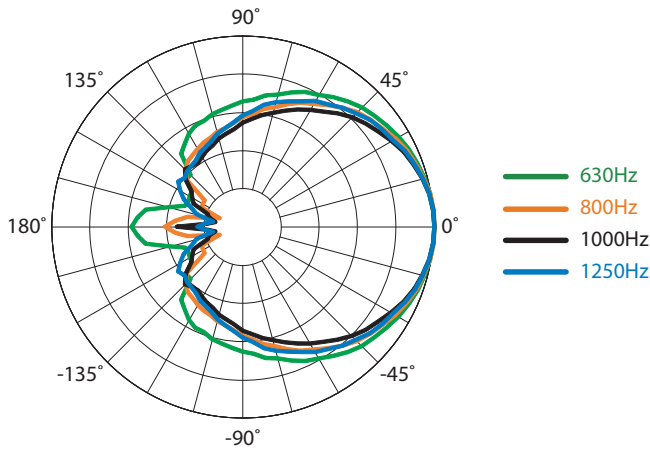
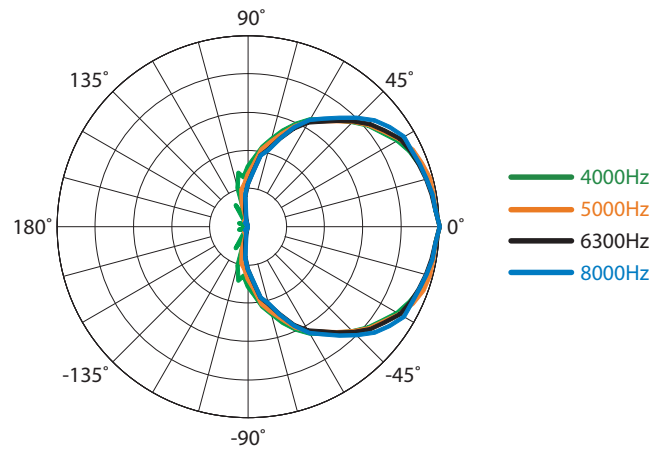
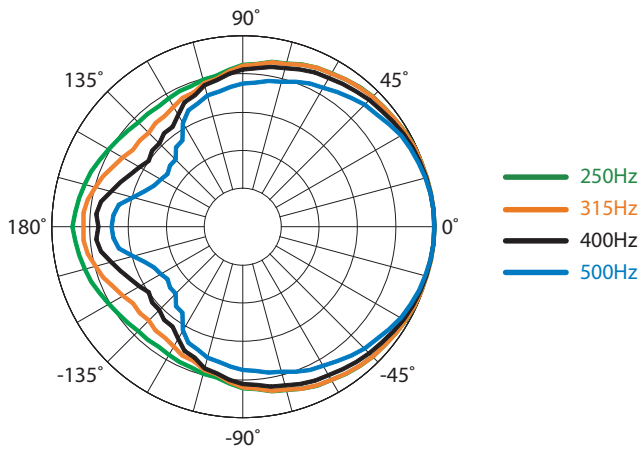
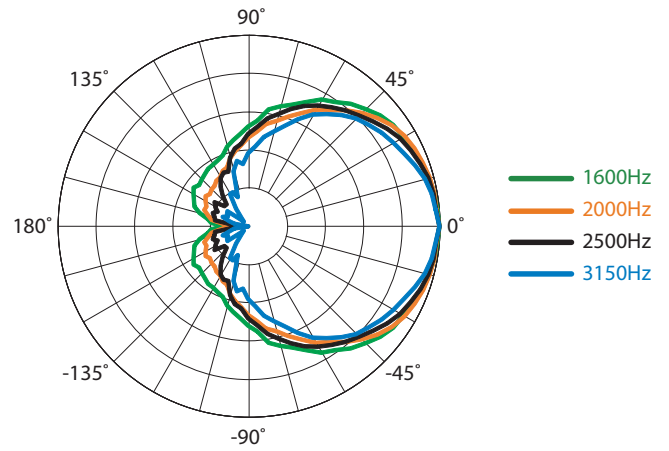
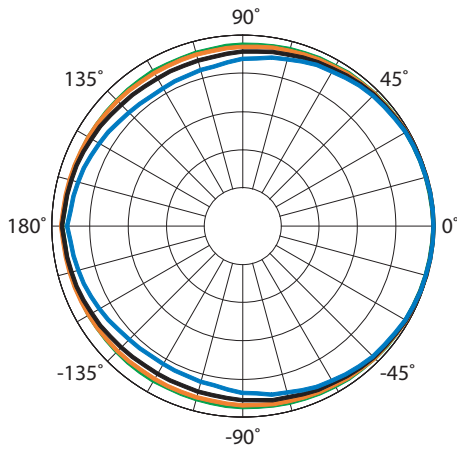

# VFM129i Specifications

## VERTICAL POLAR DATA

See *NOTES GRAPHIC DATA* for details

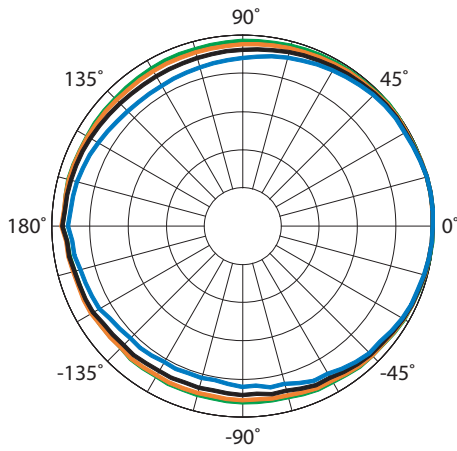

- 100Hz
- 125Hz
- 160Hz
- 200Hz

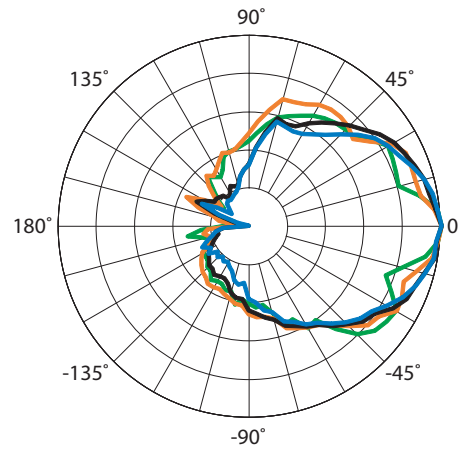

- 1600Hz
- 2000Hz
- 2500Hz
- 3150Hz

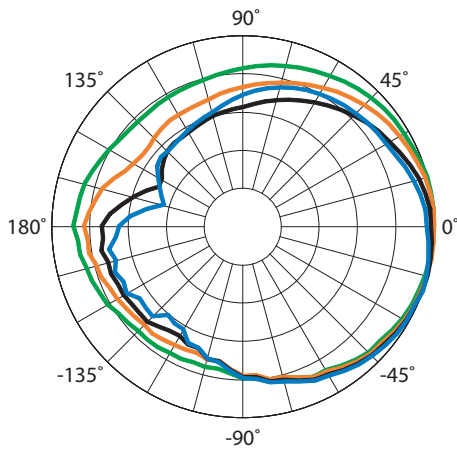

- 250Hz
- 315Hz
- 400Hz
- 500Hz

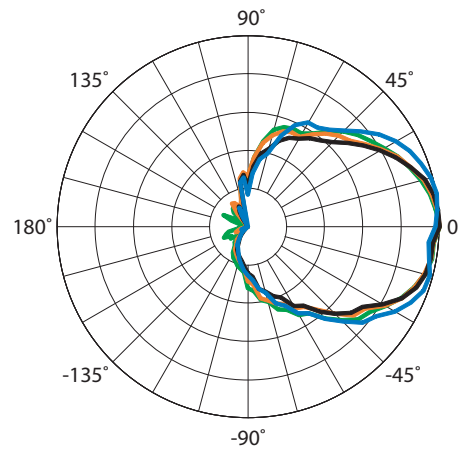

- 4000Hz
- 5000Hz
- 6300Hz
- 8000Hz

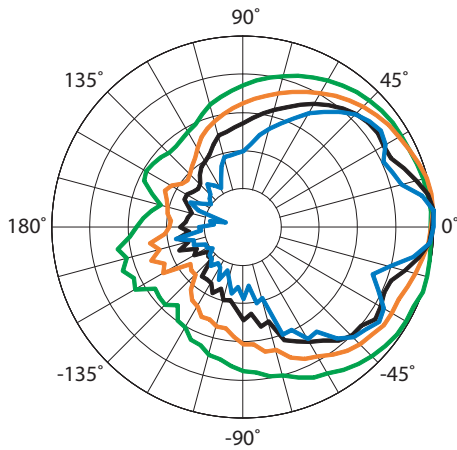

- 630Hz
- 800Hz
- 1000Hz
- 1250Hz

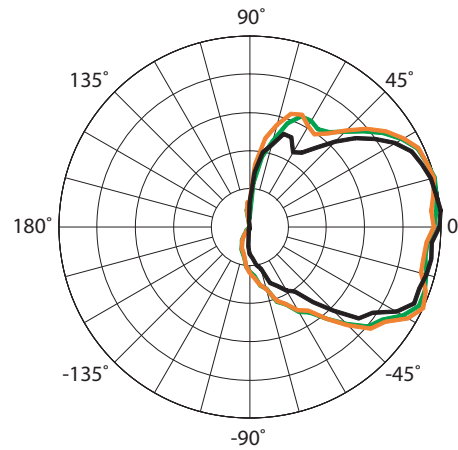

- 10000Hz
- 12500Hz
- 16000Hz

# VFM129i Specifications

## INPUT

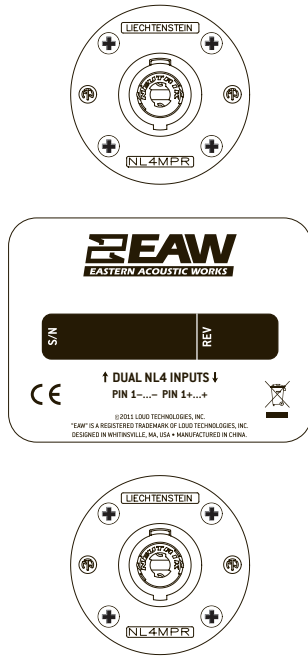

## SIGNAL DIAGRAM

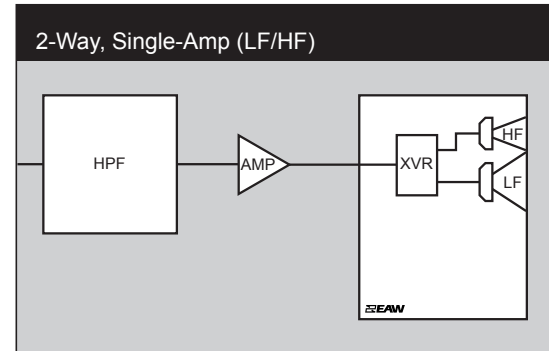

## LEGEND

- HPF:** High Pass Filter for crossover –or– Recommended High Pass Filter.
- LPF:** Low Pass Filter for crossover.
- LF/MF/HF:** Low Frequency / Mid Frequency / High Frequency.
- AMP:** User Supplied Power Amplifier –or– Integral Amplifier for NT products.
- XVR:** Passive LPFs, HPFs, and EQ integral to the loudspeaker.

## NOTES

### TABULAR DATA

- Measurement/Data Processing Systems:** Primary - FChart: proprietary EAW software; Secondary - Brüel & Kjær 2012.
- Microphone Systems:** Earthworks M30; Brüel & Kjær 4133
- Measurements:** Dual channel FFT; length: 32 768 samples; sample rate: 48 kHz; logarithmic sine wave sweep.
- Measurement System Qualification** (includes all uncertainties): SPL: accuracy +/-0.2 dB @ 1 kHz, precision +/-0.5 dB 20 Hz to 20 kHz, resolution 0.05 dB; Frequency: accuracy +/-1 %, precision +/-0.1 Hz, resolution the larger of 1.5 Hz or 1/48 octave; Time: accuracy +/-10.4  $\mu$ s, precision +/-0.5  $\mu$ s, resolution 10.4  $\mu$ s; Angular: accuracy +/-1°, precision +/-0.5°, resolution 0.5°.
- Environment:** Measurements time-windowed and processed to eliminate room effects, approximating an anechoic environment. Data processed as anechoic or fractional space, as noted.
- Measurement Distance:** 7.46 m. Acoustic responses represent complex summation of the subsystems at 20 m. SPL is referenced to other distances using the Inverse Square Law.
- Enclosure Orientation:** For beamwidth and polar specifications, as shown in Mechanical Specification drawing.
- Volts:** Measured rms value of the test signal.
- Watts:** Per audio industry practice, "loudspeaker watts" are calculated as voltage squared divided by rated nominal impedance. Thus, these are not True Watt units of energy as defined by International Standard.
- SPL:** (Sound Pressure Level) Equivalent to the average level of a signal referenced to 0 dB SPL = 20 microPascals.
- Subsystem:** This lists the transducer(s) and their acoustic loading for each passband. Sub = Subwoofer, LF = Low Frequency, MF = Mid Frequency, HF = High Frequency.
- Operating Mode:** User selectable configurations. Between system elements, a comma (,) = separate amplifier channels; a slash (/) = single amplifier channel. DSP = Digital Signal Processor. IMPORTANT: To achieve the specified performance, the listed external signal processing must be used with EAW-provided settings.
- Operating Range:** Range where the processed Frequency Response stays within -10 dB SPL of the power averaged SPL within this range; measured on the geometric axis. Narrow band dips are excepted.
- Nominal Beamwidth:** Design angle for the -6 dB SPL points, referenced to 0 dB SPL as the highest level.
- Axial Sensitivity:** Power averaged SPL over the Operating Range with an input voltage that would produce 1 W at the nominal impedance; measured with no external processing on the geometric axis, referenced to 1 m.
- Nominal Impedance:** Selected 4, 8, or 16 ohm resistance such that the minimum impedance point is no more than 20% below this resistance over the Operating Range.
- Accelerated Life Test:** Maximum test input voltage applied with an EIA-426B defined spectrum; measured with recommended signal processing and Recommended Protection Filter.
- Calculated Axial Output Limit:** Highest average and peak SPLs possible during the Accelerated Life Test. The Peak SPL represents the 2:1 (6 dB) crest factor of the Life Test signal.
- High Pass Filter:** This helps protect the loudspeaker from excessive input signal levels at frequencies below the Operating Range.

### GRAPHIC DATA

- Resolution:** To remove insignificant fine details, 1/12 octave cepstral smoothing was applied to acoustic frequency responses and 1/3 octave cepstral smoothing was applied to the beamwidth and impedance data. Other graphs are plotted using raw data.
- Frequency Responses:** Variation in acoustic output level with frequency for a constant input signal. Processed: normalized to 0 dB SPL. Unprocessed inputs: 2 V (4 ohm nominal impedance), 2.83 V (8 ohm nominal impedance), or 4 V (16 ohm nominal impedance) referenced to a distance of 1 m.
- Processor Response:** The variation in output level with frequency for a constant input signal of 0.775 V = 0 dB reference.
- Beamwidth:** Average angle for each 1/3 octave frequency band where, starting from the rear of the loudspeaker, the output first reaches -6 dB SPL referenced to 0 dB SPL as the highest level. This method means the output may drop below -6 dB SPL within the beamwidth angle.
- Impedance:** Variation in impedance magnitude, in ohms, with frequency without regard to voltage/current phase. This means the impedance values may not be used to calculate True Watts (see 9 above).
- Polar Data:** Horizontal and vertical polar responses for each 1/3 octave frequency band 100 Hz to 16 kHz or Operating Range.